

# Forward 7000 B

## Two Post Lift

**7000 LB CAPACITY**



**Forward  
Manufacturing**

AN AMERICAN INDIAN COMPANY  
PRECISION MANUFACTURING SINCE 1968

A Forward Lift is your assurance of progressive technology and proven reliability.

25 years of manufacturing experience goes into each lift.

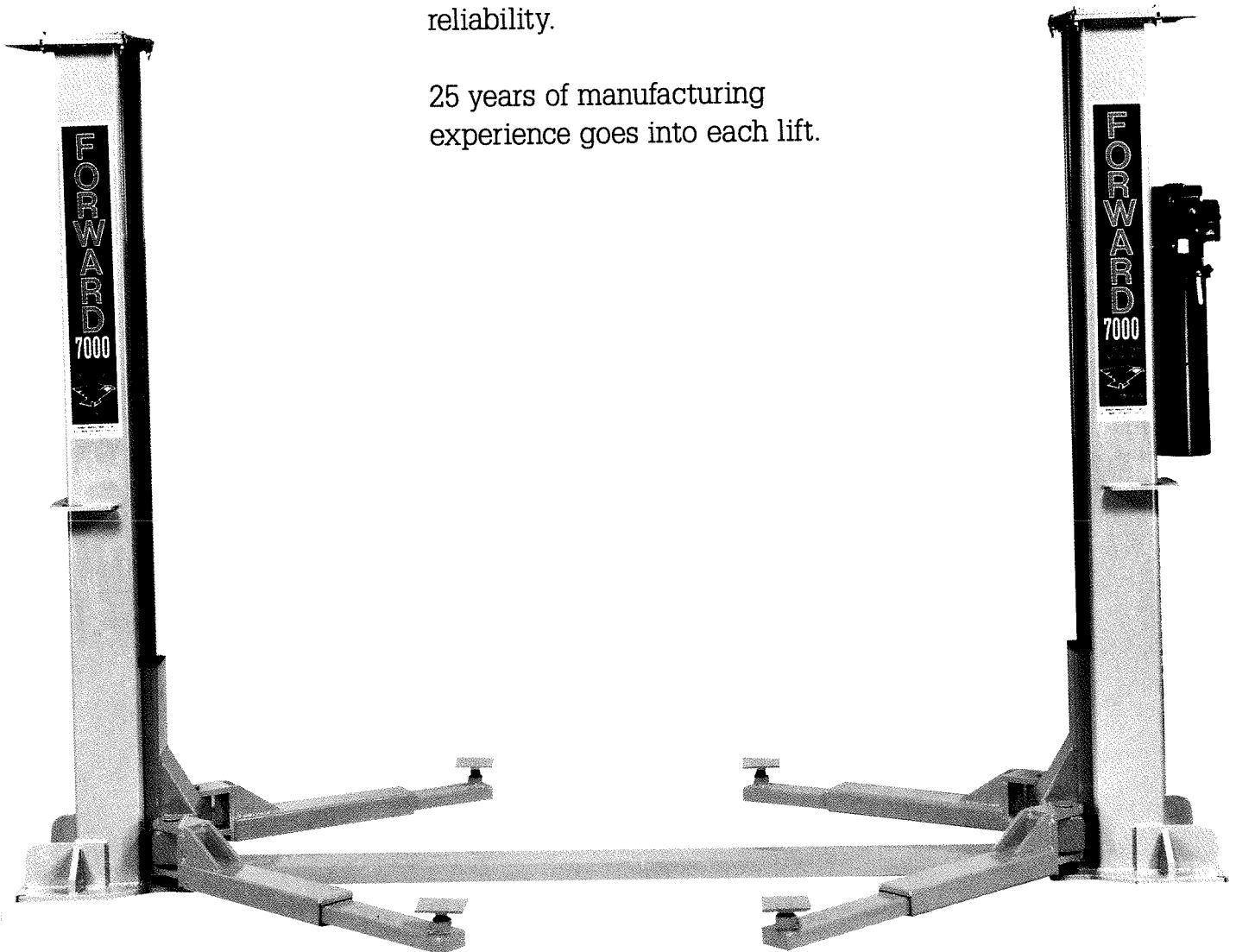

**ENGINEERED TO PERFORM - BUILT TO LAST**

# MODEL 7000 SPECIFICATIONS

Maximum Capacity .....	7000 lb.
Overall Width .....	11', 6"
Height of Lift .....	72"
Power Unit 2 H.P. Single Phase .....	208-230V. 60 Cycle
Speed of Rise .....	50 Sec.
Clearable Width Between Post .....	9', 3"
Shipping Weight .....	1,800 lb.

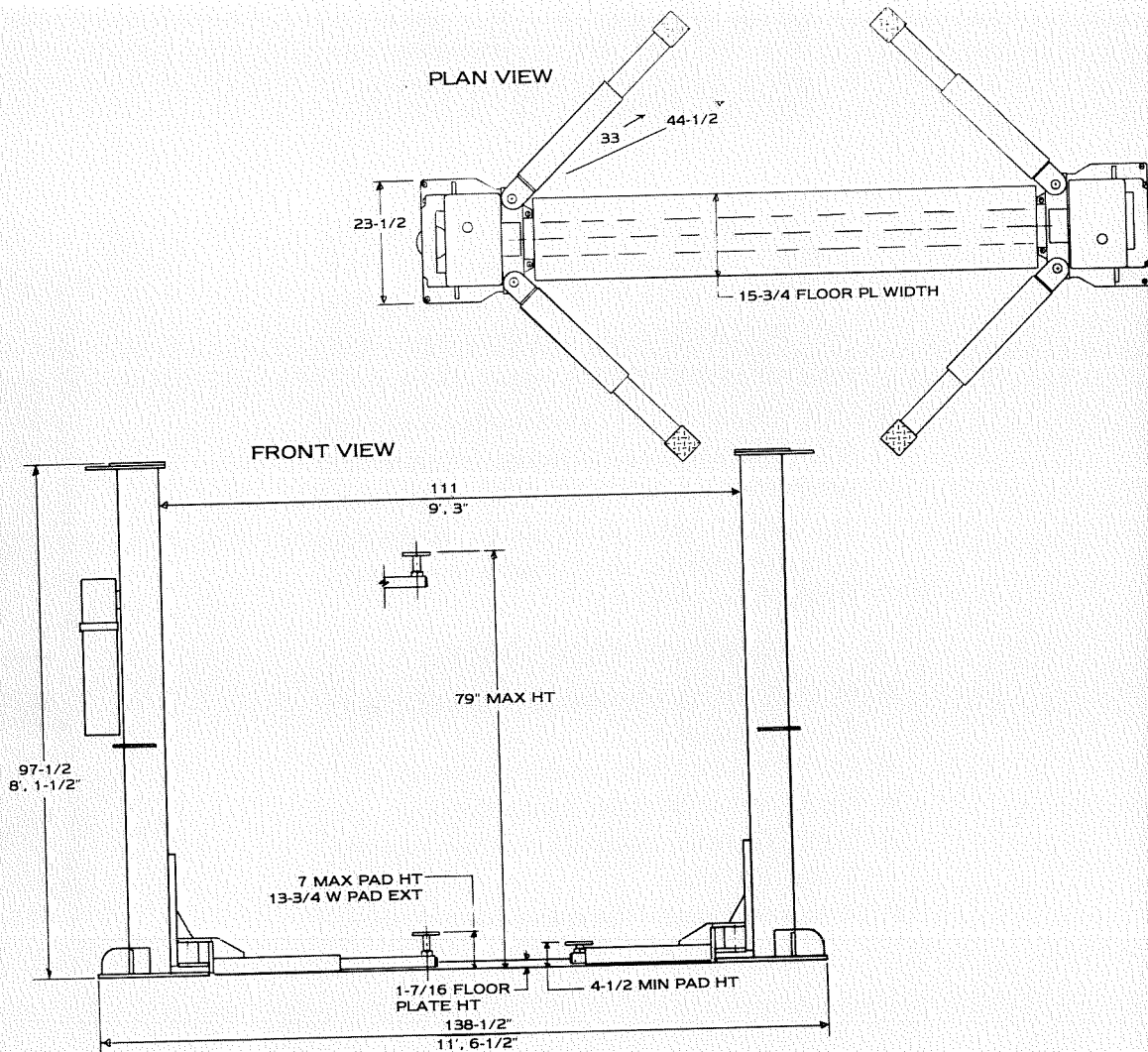

**MODEL 7000**

**FORWARD MANUFACTURING COMPANY**

3010 SOUTH MAIN  
FORT WORTH, TEXAS 76110

IN TEXAS CALL: 817-921-3523  
CALL FREE 1-800-423-1722

# FORWARD MANUFACTURING COMPANY

3010 SOUTH MAIN  
FORT WORTH, TEXAS 76110

**MANUFACTURERS OF QUALITY AUTOMOTIVE LIFTS**

## 7000 LB. CAPACITY LIFT

- A **FORWARD** lift is your assurance of progressive technology and proven reliability.
- 20 years of manufacturing experience have gone into each and every lift. All lifts meet or exceed all A.N.S.I. safety requirements and carry a 5-year limited warranty.

### SPECIAL FEATURES

- Heavy Duty Hydraulic Cylinders in Each Column
- Safety Latches in Each Column
- Quick and Simple Installation
- High Tensile Leaf Chain for Heavy Duty Service
- Lowest Floor Plate in the Industry



SEE REVERSE SIDE FOR LIFT SPECIFICATIONS

CALL TOLL FREE 1-800-423-1722 — IN TEXAS 817-921-3523

# FORWARD MANUFACTURING COMPANY

## TWO POST LIFT

### MODEL 7000

*Cable 992601*

## INSTALLATION & OPERATOR'S MANUAL

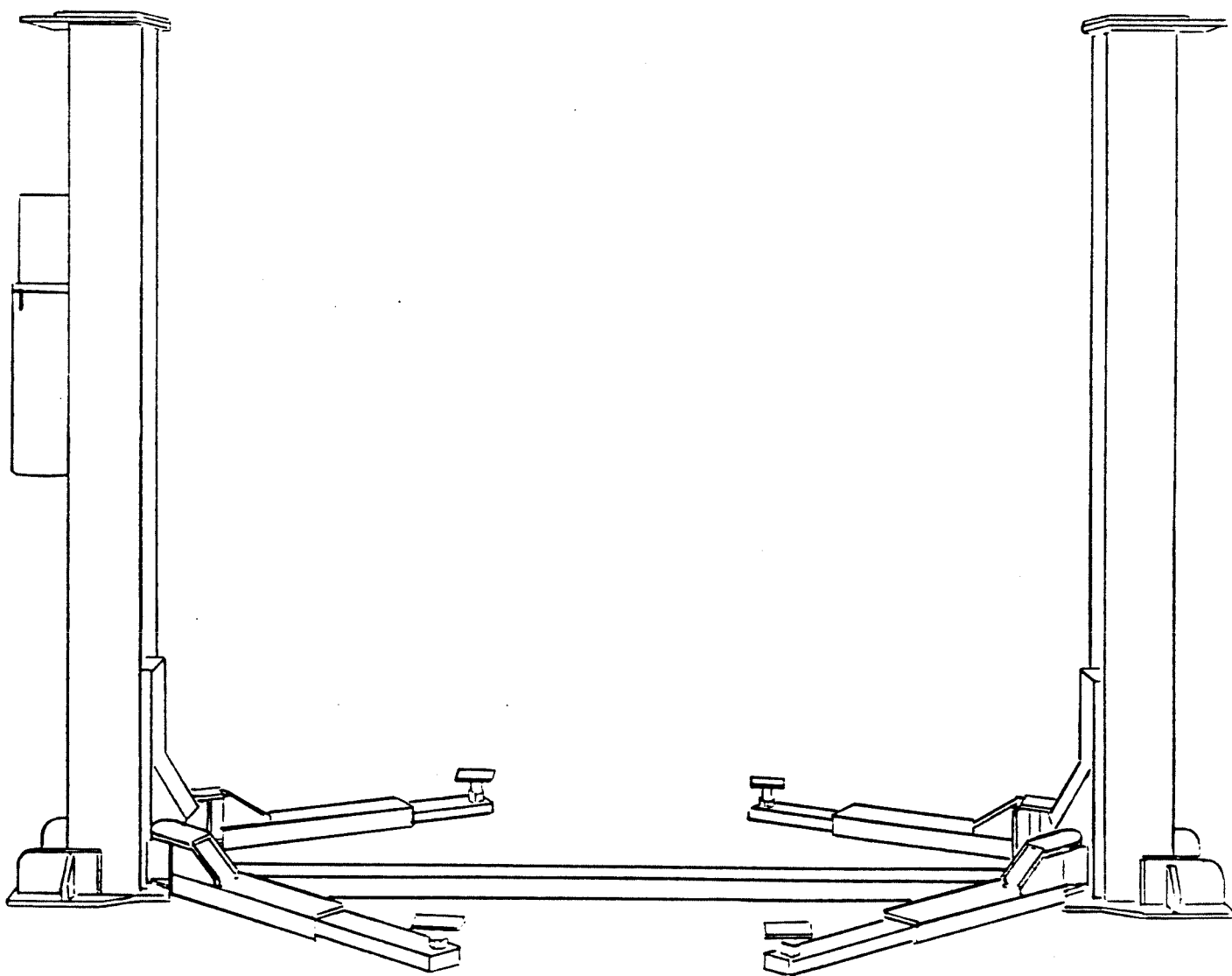

I MAN 991001

FORWARD MANUFACTURING COMPANY

TWO POST LIFT

MODEL 7000

INSTALLATION & OPERATOR'S MANUAL

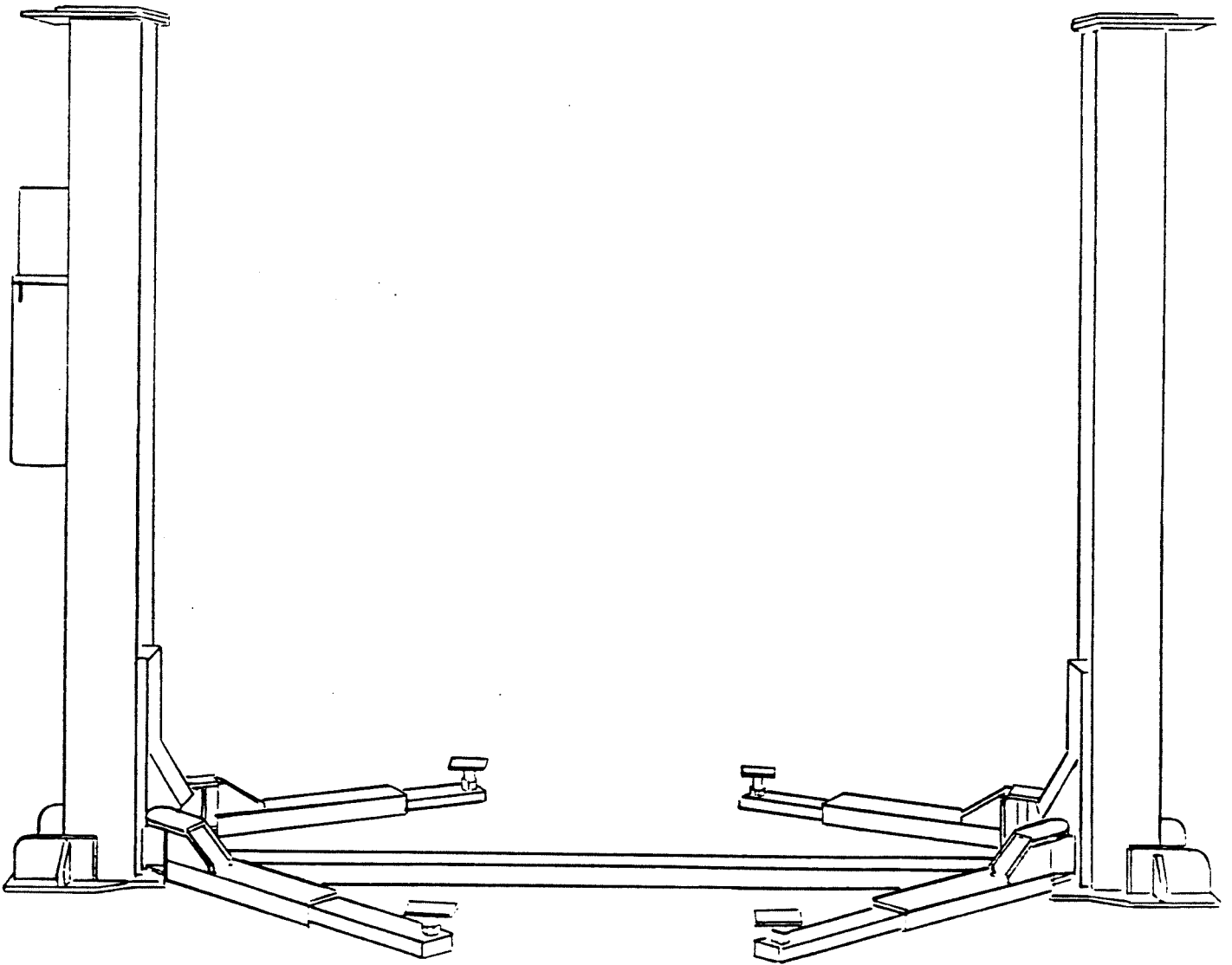

I MAN 991001

TWO POST INSTALLATION MANUAL

MODEL 7000  
I MAN 991001

10/93

IMPORTANT NOTICE:

THE FLOOR ON WHICH THE LIFT IS TO BE INSTALLED MUST BE 4 INCH MINIMUM THICKNESS CONCRETE, WITH A MINIMUM COMPRESSIVE STRENGTH OF 3000 PSI, AND REINFORCED WITH STEEL MESH OR BAR.

FAILURE BY THE PURCHASER TO PROVIDE THE RECOMMENDED MOUNTING SURFACE COULD RESULT IN UNSATISFACTORY LIFT PERFORMANCE, PROPERTY DAMAGE, OR PERSONAL INJURY.

IMPORTANT:

READ THIS INSTRUCTION MANUAL BEFORE INSTALLING THE LIFT.

READ THE ANCHOR BOLT INSTRUCTION PAGE BEFORE DRILLING AND INSTALLING THE CONCRETE ANCHOR BOLTS.

INSTALL A 220 VOLT, 20 AMP TWIST LOCK PLUG IN THE ELECTRICAL LINE JUST BEFORE THE MOTOR ELECTRICAL BOX. IF THE POWER UNIT PUSH BUTTON SWITCH SHOULD STICK IN THE ON POSITION, THIS PLUG CAN BE OPENED TO STOP THE MOTOR.

DO NOT RAISE A VEHICLE ON THE LIFT UNTIL THE LIFT HAS BEEN CORRECTLY INSTALLED AND ADJUSTED AS DESCRIBED IN THIS MANUAL.

VEHICLES MUST BE POSITIONED ON THE LIFT SO THAT THEY ARE BALANCED FROM FRONT TO REAR ON THE ARMS.

DO NOT REMOVE A TRANSMISSION, SUSPENSION ASSEMBLY, OR OTHER HEAVY ITEM FROM THE FRONT OF A FRONT WHEEL DRIVE VEHICLE UNLESS THE VEHICLE IS ADEQUATELY SUPPORTED IN THE REAR. SEE FIGURE 3.

TABLE OF CONTENTS

Tools Required For Installation.....Page 2.

Installation Instructions.....Page 3.

Maintenance Instructions.....Page 8.

Operating Tips.....Page 8.

Concrete Anchor Bolt Instructions.....Page 9.

Troubleshooting Instructions:

- 1. Lift does not operate smoothly.....Page 10.
- 2. Lift does not pick up rated load.....Page 10.
- 3. Lift does not come down.....Pages 10-12.
- 4. Cylinders leak down.....Page 13.
- 5. Power unit switch sticks.....Page 13.
- 6. Oil leaks.....Page 13.

Figure 1, Two Post Lift Placement.....Page 14.

Figure 2, Two Post Cable Installation.....Page 15.

Figure 3, Front Wheel Drive Vehicle Precautions....Page 16.

Figure 4, Electrical Wiring Diagram.....Page 17.

Figure 5, Arm Lock Assembly.....Page 18.

## TOOLS FOR INSTALLATION

Concrete hammer drill with 3/4" solid drill bit with carbide tip to ANSI standard B94.12-1977.  
11/16" open end wrench  
3/4" open end wrench  
3/4" socket with ratchet drive  
1-1/16" deep socket  
1-1/8" socket or wrench  
Level (18" length)  
Vise grips  
Tape measure  
Funnel  
Hoist or forklift

## ALSO REQUIRED FOR INSTALLATION:

3 gallons of petroleum base (mineral) hydraulic oil, non foaming, non detergent, approximately 10 wt, such as Mobil DTE 25 or Texaco HD 46.



## INSTALLATION

1. Remove the shipping bands. Remove the floor plate from the top of the lift. Remove the swing arms. Remove loose items from the inside of the bottom leg.
2. Remove the four 1/2" bolts which hold the two legs together. Remove the top leg.
3. Refer to Figure #1, Two Post Lift Placement, to determine the location for the mainside leg, which has 4 drilled holes in the back for the power unit installation. Position the leg at this spot.
4. Position the floor plate at the front of the mainside leg, aligning the holes of the plate end with the front holes of the leg base. Be certain that the leg and plate are square with the mounting location. Using a 3/4" concrete drill, drill holes at these two front holes. SEE THE CONCRETE ANCHOR BOLT INSTRUCTION PAGE FOR DRILLING INFORMATION. Drive two anchor bolts into the holes. Do not tighten the nuts at this time.
5. Locate the offside leg at the other end of the floor plate. Line up the front holes of the leg with the holes in the end of the floor plate. Make sure the two legs and the plate are square with each other. Drill the two front holes using the concrete drill. SEE THE CONCRETE ANCHOR BOLT INSTRUCTION PAGE FOR DRILLING INFORMATION. Drive two anchor bolts into the holes. Do not tighten the nuts at this time.
6. Drill the remaining eight holes in the two legs and install the anchor bolts. Do not tighten the nuts at this time. Remove the floor plate from between the legs.
7. The two legs must be checked for vertical alignment both side to side and front to rear. Use a level to check this. Shim the legs as necessary to level the legs. Use the steel shims provided or 3/4" flat washers. Shim next to and on both sides of the anchor bolts. Tighten the anchor bolt nuts. See the concrete anchor bolt instruction page for tightening information.

**IMPORTANT:** The legs must be shimmed so that the bases of the legs are adequately supported. If more than 1/2" of shimming is required, fabricate larger shims from steel flat, 1/4" or 1/2" by 2" or more wide.

8. Raise the two carriages approximately two feet so that they are supported by the safety latches. The carriages must be at the same height, resting on the same safety

latch rack tooth in each leg. Measure the distance from the leg base to the bottom of each carriage. The two measurements should be within 3/8" of each other. If one carriage is low, raise it to the safety latch tooth which makes the two carriage heights approximately the same.

9. Lay out the two cable assemblies. On one end of each cable install a 3/4" SAE washer and a nylon insert nut. Thread the nut onto the cable until the nylon is engaged then stop. If the cables have a short end, install the nut on that end.
  10. Refer to Figure 2, Cross Cable Installation. Start with the mainside (power unit) leg for the cable installation. From under the carriage, run the cable end without a nut up thru the front bottom right (as you face the leg) hole up and around the large pulley at the ,leg top, down thru the rear bottom left hole of the carriage, around the bottom pulley, and across the floor to the other leg.
  11. At the offside leg, run the cable under the right (as you face the leg) pulley, up thru the bottom rear opening inside the offside carriage, and up thru the top rear hole of the carriage. See Figure #2. Secure the cable end with a 3/4 SAE washer and a 3/4 nylock nut. Do not tighten the cable nut at this time.
  12. Run the offside cable in the same manner. See Figure #2. Do not tighten the cable nut at this time.
  13. The carriages should be resting on the same safety rack tooth and the cables should be slack. The safety latch pull rods will not pull down, indicating that the weight of each carriage is on its safety latch. Measure the height above the base plate for each carriage. The measurements should be within 3/8" of each other, as determined in step 8. Make a note of the two measurements.
- IMPORTANT:** The carriages must remain at the same height while the cross cables are being tightened. Overtightening of one cable could raise the carriage in the opposite leg and cause the carriage safety latches to be out of sync.
14. Take out the slack, but do not tighten, the mainside cable by turning down the nut on the mainside carriage. Use vise grips to hold the cable end while tightening the nut. Do not damage the threads with the vise grips. Measure the offside carriage height, or check the safety latch pull rod for the carriage weight, to be sure that the carriage has not been raised.
  15. Take out the slack, but do not tighten, the offside cable

by turning down the nut on the offside carriage. Measure the mainside carriage, or check the safety latch pull rod for the carriage weight, to be sure that the carriage was not raised.

16. Alternately tighten the mainside and offside cable nuts until the cables are tightened. Correct tension in the cables is indicated by approximately 1/4" deflection of the cable in the leg when pulled at its midpoint.
17. Measure the carriage heights to verify that the carriages are within 1/8" of the original measurements noted in step 13. If a carriage has been raised more than 1/8" by the cable tightening procedure, loosen the cables and repeat the procedure.
18. Install the power unit on the mainside leg using the 4 5/16 bolts and lock nuts provided.

IMPORTANT: Install the bolts with the heads towards the leg. Secure the bolts with the 5/16 plain nuts. Install the power unit mounting flange against the plain nuts. Install the nylon insert 5/16 nuts over the mounting flange to hold the power unit.

19. Install the short hydraulic hose between the power unit and the cylinder fitting at the bottom rear of the leg.
20. Install the hydraulic hose between the two cylinders.
21. Install the floor plate between the legs and secure with the anchor bolt nuts. Do not pinch the hydraulic hose.
22. Using a funnel in the breather cap fitting on the power unit reservoir, fill the reservoir with 11 quarts of petroleum base (mineral) hydraulic oil, non foaming, non detergent, such as Mobil DTE 25 or Texaco HD 46. Install the breather cap.

DO NOT OVERFILL THE OIL TANK. The oil level should be no higher than two inches below the mounting flange of the tank. If the tank has a screw just below the tank mounting flange, remove the screw and fill until oil comes out of the hole. Replace the screw.

23. Lubricate the four inside corners of both legs with heavy duty bearing grease.
24. Install the arms on the carriages with the swing arm pins. Lubricate the swivel pad screws and install them onto the arms. Install the arm restraints. Refer to Figure 5. The bumper restraints are positioned on the rear arms.

25. Establish power hook-up to 220-1 phase power. Figure 4. Install a 220 volt, 20 amp twist lock plug in the power line just before the motor electrical box. If the push button switch should stick in the open position, this plug can be opened to stop the motor.
26. DO NOT ATTEMPT TO LIFT A VEHICLE AT THIS TIME. Verify that the lifting chains are centered on the chain rollers attached to the cylinder rams. Raise the lift approximately three feet. The lifting control is located on the power unit. The safety latches of the two carriages should "click" together as the lift goes up. If they do not, the cables should be loosened and the above procedure for tightening them should be repeated. Lower the carriages onto the safety latches. To lower the lift, first raise the carriages slightly. Pull down the two safety latch rods which are located at the bases of the carriages. Lower the lift by working the lowering control on the power unit. If there are any problems, check the Troubleshooting section of the manual.
27. DO NOT ATTEMPT TO LIFT A VEHICLE AT THIS TIME. Raise the lift to the top of its travel. Lower the carriages onto the safety latches. Lower the lift to the ground. If there are any problems, check the Troubleshooting section of this manual.

IMPORTANT: DO NOT ATTEMPT TO LIFT A VEHICLE UNTIL:

1. The cables are adjusted correctly and the carriage heights are within 1/8" of the measurements noted in step 13.
  2. The legs have been leveled and the anchor bolts have been tightened.
  3. The leg corners have been lubricated with heavy duty bearing grease.
28. The first time a vehicle is placed on the lift, raise it NO HIGHER THAN THREE FEET. Lower the vehicle onto the safety latches. Lower the vehicle to the floor using the procedure described in #26. The lift should move up and down smoothly. If there are any problems, check the Troubleshooting section of this manual. Correct any problems before continuing.
  29. Raise a vehicle to the full height and lower the carriages onto the safety latches. Lower the vehicle to the floor using the procedure described in #26. If there are any problems, check the Troubleshooting section of this manual.

30. After cycling the lift a few times with a vehicle on it, recheck the tightness of the anchor bolt nuts. Check the nuts for tightness every week for the first month and every month afterwards.
  
31. After cycling the lift a few times with a vehicle on it, recheck the tension of the cross cables by comparing the cables in the two legs for equal tension. Correct tension in the cables is indicated by approximately 1/4" deflection of the cables when pulled at their midpoints. The latches in the legs should click at the same time as the lift moves up. Should it be necessary to re-sync the carriages, first lower the carriages onto the same height safety latch tooth, then adjust the cables as described for their installation. The carriages should be kept in sync for proper operation of the safety equipment.

#### MAINTENANCE, EVERY MONTH:

1. Lubricate the four inside corners of the two legs with heavy duty bearing grease.
2. Lubricate exposed chain surfaces.
3. Check the hydraulic fluid level. If necessary add petroleum base (mineral) hydraulic oil, non foaming, non detergent, approximately 10 wt, such as Mobil DTE 25, or Texaco HD 46.  
DO NOT OVERFILL THE OIL TANK. The oil level should be two inches below the mounting flange of the tank.  
If the tank has a screw just below the top of the tank, remove the screw and fill until oil comes out of the hole. Replace the screw.
4. Check cable tension. See Installation Instructions for adjustment procedure if required.
5. Check anchor bolt nut tightness. If the anchor bolts are excessively loose, check more often.

#### OPERATING TIPS:

1. Keep the four inside corners of the legs lubricated with heavy duty bearing grease.
2. Position vehicles so that the load is evenly balanced on the lift.
3. If the carriages get out of sync (do not click at the same time), readjust the cables as described in the installation instructions.
4. Check the anchor bolt tightness every month.
5. Do not remove the transmission, suspension assemblies, or other heavy items from the front end of front wheel drive vehicles without supporting the rear of the vehicle. See Figure #3.

## TROUBLESHOOTING

1. THE VEHICLE DOES NOT MOVE UP AND DOWN SMOOTHLY.
  1. Check the four inside corners of the two legs for roughness. Any rust or burrs must be removed with 120 grit emery paper. The surfaces must be smooth.
  2. Lubricate the leg corners with heavy duty bearing grease.
  3. Check the legs for vertical alignment both side to side and front to rear. Use a level to check this. Shim the legs as necessary to level the legs. Use steel 3/4" washers or 2"x 3"x 1/16" or 1/8" steel flat strips. Shim next to and on both sides of the anchor bolts.

IMPORTANT: The legs must be shimmed so that the bases of the legs are adequately supported. If more than 1/2" of shimming is required, fabricate shims from 1/4" or 1/2" by 2" or wider steel flat.

4. Adjust vehicle placement on the lift for equal weight distribution.

IMPORTANT: If a vehicle does not go up smoothly, do not continue to raise it. Lower the vehicle and correct the problem.

2. THE LIFT WILL NOT PICK UP ITS RATED LOAD.
  1. Adjust vehicle placement on the lift for equal weight distribution.
  2. Relief valve settings are not adjustable. Check that the correct power unit is furnished with the lift.
  3. If the motor bogs down while running, it indicates a possible low voltage situation. A minimum of 208 volts are required at the motor. Check this while the motor is running under load.
3. THE LIFT WILL NOT LOWER. The lift will move down approximately 1", then it stops. Check the safety latch pull rods. If one of the rods has moved back up, that carriage is resting on its safety latch. See also #4 and #5 under Troubleshooting.

## CONCRETE ANCHOR BOLT INSTRUCTIONS

### DRILLING PROCEDURE

1. The anchor bolts must be installed at least 5" from any edge of the concrete or any seam.
2. Use a CARBIDE TIP, SOLID DRILL BIT the same diameter as the anchor, 3/4". TIP DIAMETER TO ANSI STANDARD B94.12-1977. (.775 to .787 INCHES DIAMETER)
3. Use a concrete hammer drill.
4. Do not use excessively worn bits or bits which have been incorrectly sharpened.
5. Keep the drill in a perpendicular line while drilling.
6. Let the drill do the work. Do not apply excessive pressure.
7. Lift the drill up and down to remove dust and reduce binding.
8. Drill the hole to a depth equal to the full length of the fastener, or completely thru the slab.
9. Blow out the dust from the hole. This increases the holding power.

### INSTALLATION

1. Drill the hole equal to the length of the anchor bolt, or thru the slab.
2. Assemble the washer and nut onto the anchor bolt. Thread the nut approximately 4/5's of the way onto the anchor bolt. Using a hammer on the nut, CAREFULLY tap the anchor bolt into the concrete. Do not damage the nut or the threads.
3. Insert the bolt so that the washers rest against the base of the lift.
4. Tighten the nut, two to three turns on average concrete, 28-day cure. If the concrete is very hard, only one to two turns may be required.



Explanation: The pull rod is out of adjustment and is rubbing on the leg. When the carriage is lowered, the rod is pulled in, engaging the safety latch.

To lower lift:

1. Raise the carriages slightly to clear the safety latches.
  2. Pull the safety latches out. Use a rolled up shop rag inserted between the pull rod and the carriage to hold the rod out.
  3. Lower the lift.
  4. Adjust the rod to clear the leg. This is accomplished by pushing down on the first bend of the rod just inside the leg. Bend the rod slightly to allow it to move freely inside the leg.
4. THE LIFT WILL NOT LOWER. The vehicle is at the top of the lift's travel and one safety latch will not disengage to allow the lift to lower. See also #3 and #5 under Troubleshooting.

Explanation: The carriages are out of sync. The carriage which is 'low' cannot be raised enough to clear the latch-rack so that it can be disengaged. This is confirmed by the inability to pull down the latch rod on that carriage. Also the carriages do not 'click' at the same time as the lift is raised.

To lower lift:

1. Raise the lift to full height.
2. Push IN both safety pull rods to engage the safety latches.
3. Use a hydraulic jack and a length of pipe to raise the low carriage enough to disengage the safety latch. It may be necessary to loosen the cable nut on that carriage. Pull the latch rod on that carriage only.
4. Remove the jack and pipe.
5. Pull the latch rod on the other carriage to disengage its safety.

6. Lower the lift and remove the vehicle.
  7. Readjust the cables as described in the installation part of the manual.
5. THE LIFT WILL NOT LOWER. The vehicle may or may not be at the top of the lift's travel. Both safety latches are disengaged but the lift will not lower. See also #3 and #4 under Troubleshooting.

Explanation: Roughness in the leg corners and/or lack of lubrication and/or unequal vehicle weight distribution have resulted in too much friction to lower the lift. This is an extreme case of #1 under Troubleshooting, where the lift does not move smoothly. If the vehicle did not go up smoothly this is probably the reason the lift will not lower.

To lower lift:

1. Confirm that the carriages are supported by the cylinders. Do this by briefly energizing the power unit. If the carriages move up slightly, they are supported by the cylinders. If the carriages are at the top of their travel, the cylinders will top out and the power unit will squeal as the relief valve opens.
2. Push IN the safety pull rods to insure that the latches are engaged.
3. Apply grease lubrication to leg corners beneath the carriages.
4. Determine which end of the lift is heavy due to vehicle position and which end is light.

DO NOT CONTINUE UNLESS THE CARRIAGES ARE SUPPORTED BY THE CYLINDERS. SEE #1 IMMEDIATELY ABOVE.

5. Pull out the safety pull rods to disengage both safety latches.
6. Use one or more helpers to pull down on the light end of the vehicle on the lift.

DO NOT ALLOW PERSONNEL AROUND THE HEAVY END OF THE LOAD DURING THIS PROCEDURE.

7. With the load in a more balanced condition,

lower the lift.

IF THE LIFT WILL NOT LOWER, DO NOT ALLOW THE CYLINDERS TO DROP MORE THAN 1/4". THE CARRIAGES MUST NOT BE ALLOWED TO DROP WITHOUT BEING SUPPORTED BY THE CYLINDERS. USE ADDITIONAL HELPERS TO PULL DOWN ON THE LIGHT END OF THE LOAD. REPEAT THE PROCEDURE.

6. CYLINDERS LEAK DOWN.

There may be some trash in the check valve which prevents the valve from seating. Hold open the lowering valve while energizing the motor switch. Allow the motor to run for 30 seconds to flush the valve. Repeat 3 or 4 times. If the cylinders continue to leak down, the valve may be faulty. Contact the lift manufacturer.

7. POWER UNIT SWITCH WILL NOT RELEASE.

Contact the lift manufacturer for a replacement switch. Install a 220 volt, 20 amp twist lock plug in the electrical line just before the power unit motor electrical box. If the power unit push button should stick in the closed position, this plug can be opened to stop the motor.

8. OIL LEAKS:

1. Power Unit. If the power unit leaks hydraulic oil around the tank mounting flange, check the oil level in the tank. The level should be two inches below the flange of the tank. Remove the fill level screw just below the tank flange and drain excess oil.

2. Cylinder top. If the cylinder leaks hydraulic oil at the top or out of the breather, the piston seal is leaking. Contact the factory.

3. Cylinder bottom. If the cylinder leaks oil around the base, check the fittings on both the front and back of the cylinder. Check the fittings for tightness. If the threads continue to leak, remove the fitting, reapply teflon tape, and reinstall the fitting.

Approx. 9' to nearest obstacle

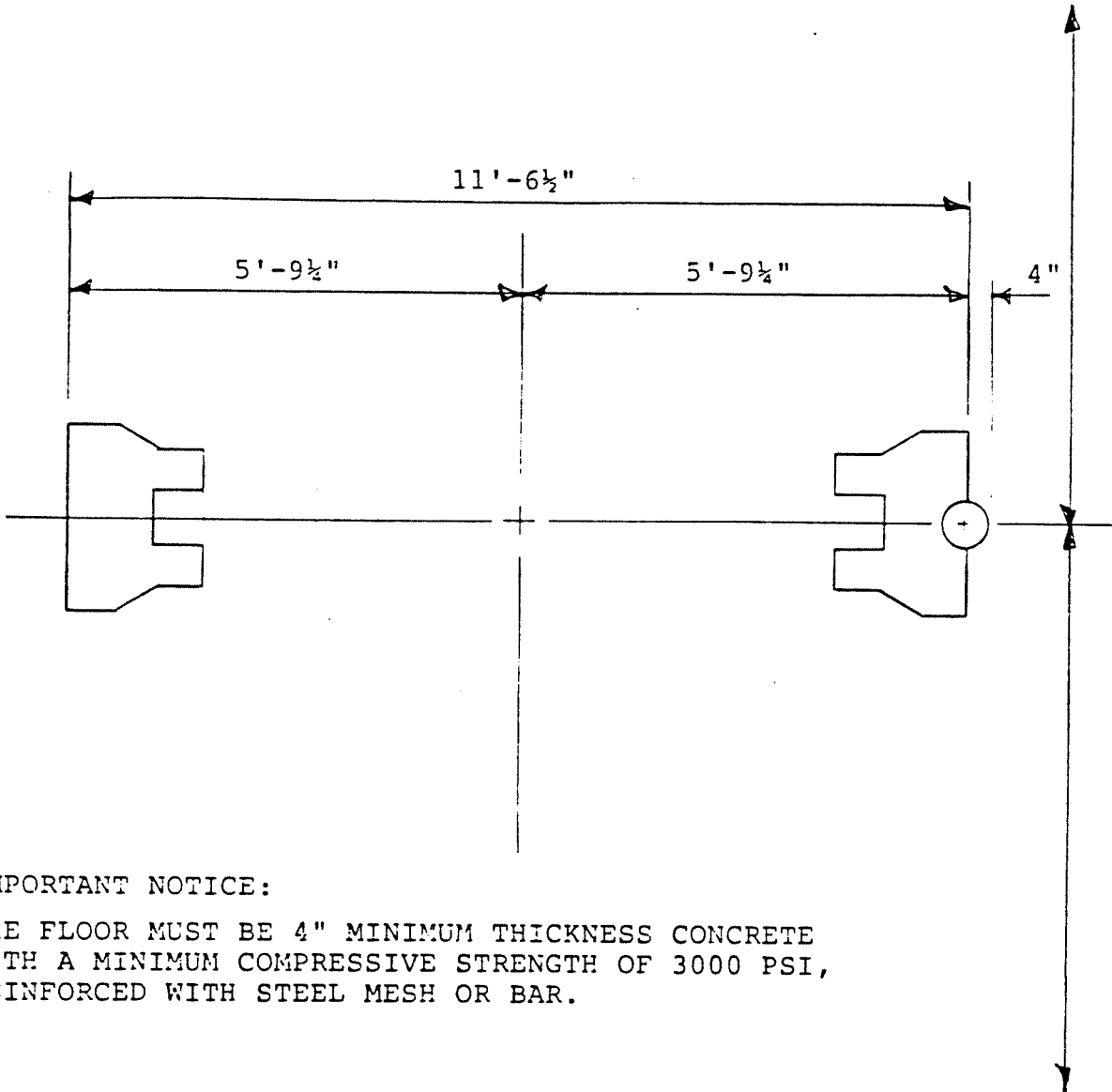

**IMPORTANT NOTICE:**

THE FLOOR MUST BE 4" MINIMUM THICKNESS CONCRETE WITH A MINIMUM COMPRESSIVE STRENGTH OF 3000 PSI, REINFORCED WITH STEEL MESH OR BAR.

Approx 8' to nearest obstacle

12' Required for alignment tracks.

FIGURE #1  
TWO POST LIFT PLACEMENT

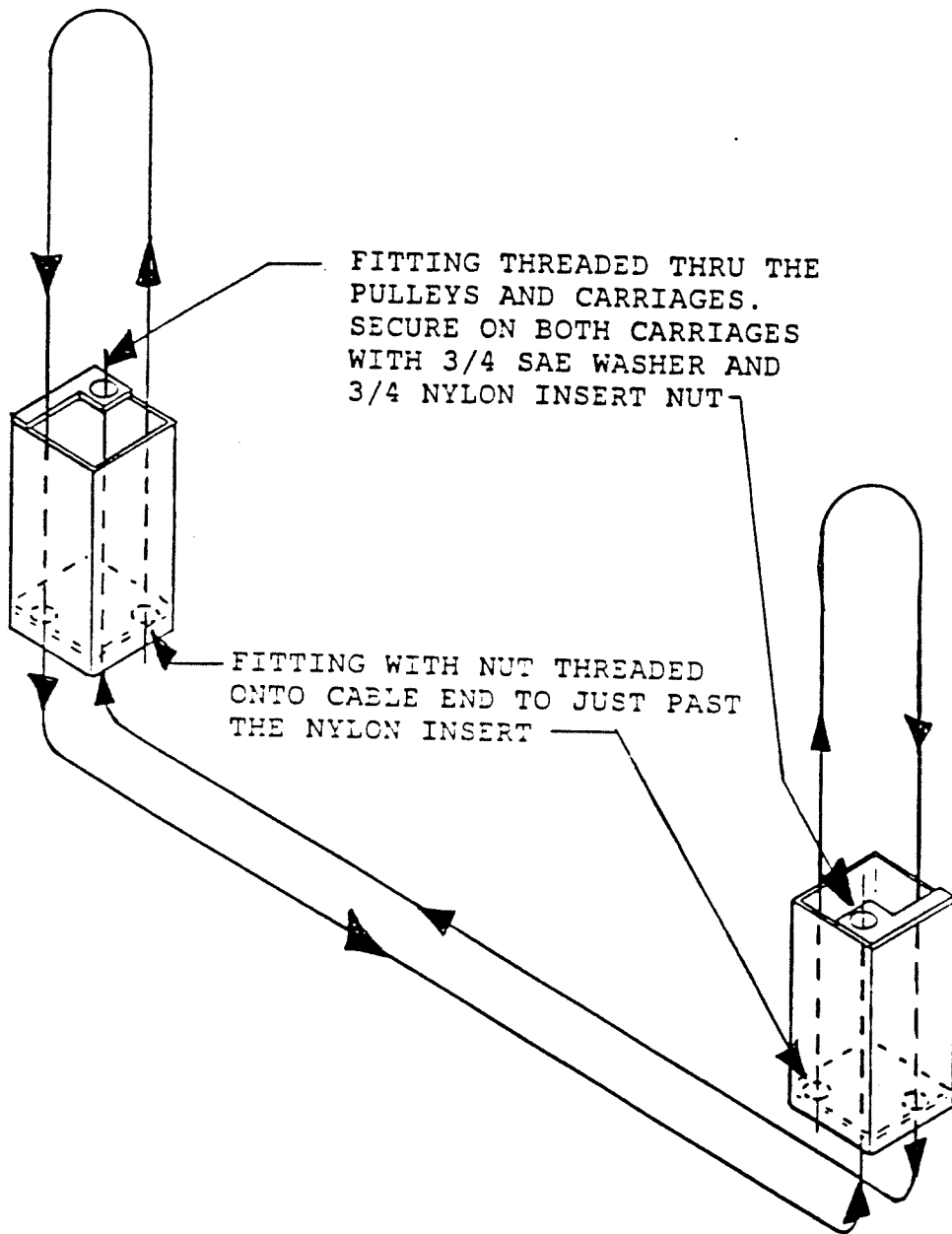

FITTING THREADED THRU THE PULLEYS AND CARRIAGES. SECURE ON BOTH CARRIAGES WITH 3/4 SAE WASHER AND 3/4 NYLON INSERT NUT

FITTING WITH NUT THREADED ONTO CABLE END TO JUST PAST THE NYLON INSERT

FIGURE 2  
CROSS CABLE INSTALLATION

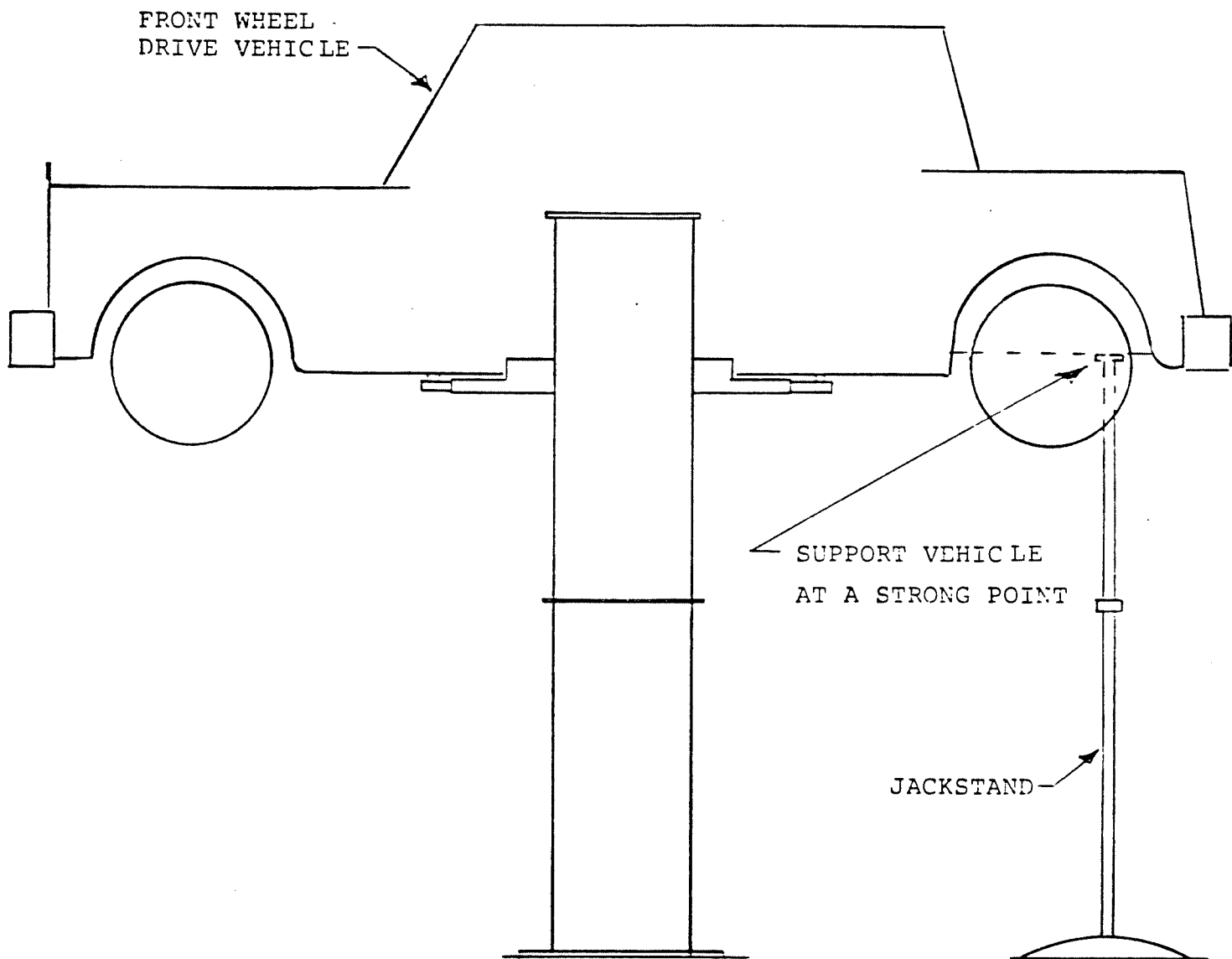
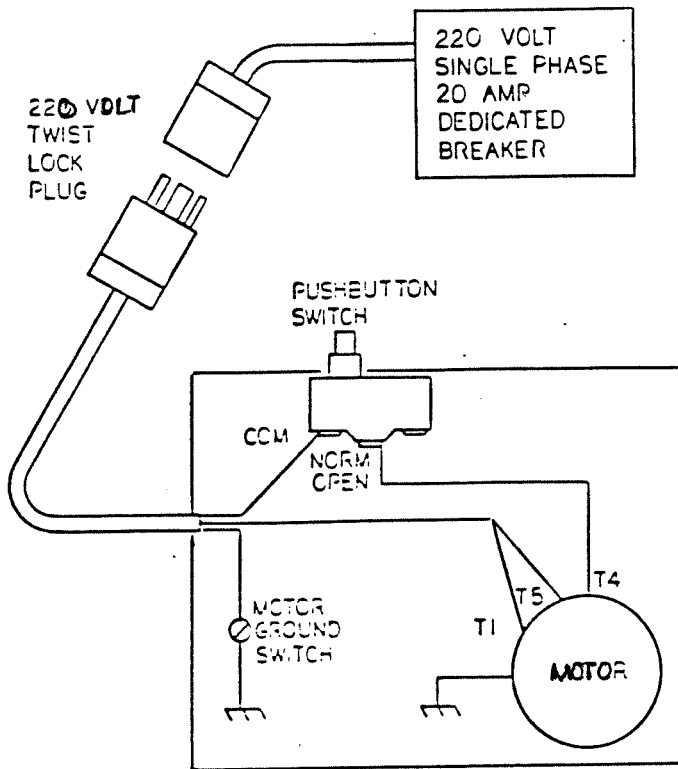
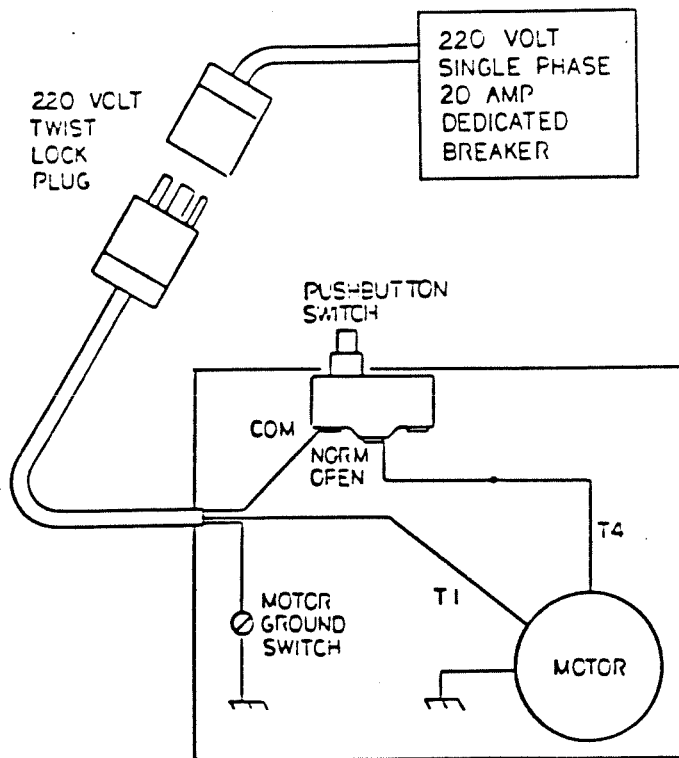

FIGURE #3

SUPPORT THE REAR OF A FRONT WHEEL DRIVE VEHICLE BEFORE  
REMOVING HEAVY ASSEMBLIES FROM THE FRONT OF THE VEHICLE



WIRING DIAGRAM: EARNES POWER UNIT



WIRING DIAGRAM: FENNER POWER UNIT

FIGURE 4: MODEL 7000 ELECT. WIRING DIAGRAM

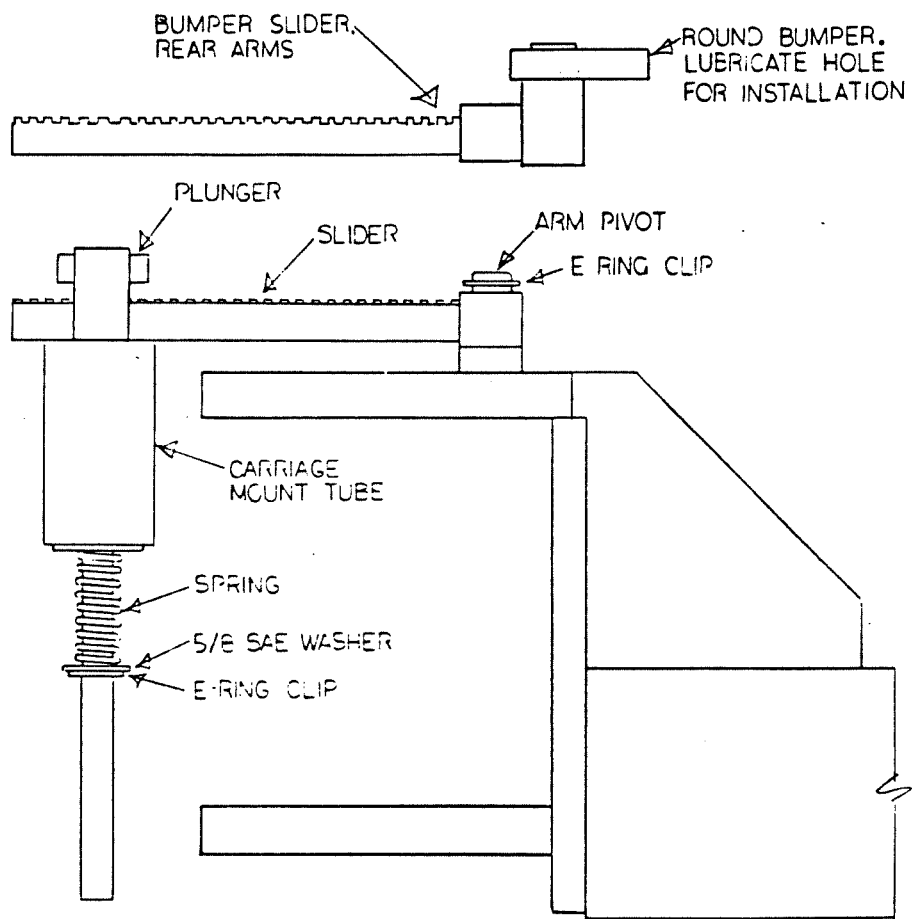

FIGURE 5  
 ARM LOCK ASSEMBLY





## WARRANTY

All Forward Manufacturing Company (*FORWARD*) surface-mounted lifts are guaranteed to the original owner for five years from invoice date. *FORWARD* will repair or replace, for the full five years, those parts returned to the factory which prove, upon inspection by *FORWARD*, to be defective. *FORWARD* will pay for reasonable costs of transportation and labor for the replacement of said parts for the first twelve (12) months only. The Purchaser will bear costs of transportation after the first year and the remainder of this warranty. This warranty will not apply unless the product is installed, used and maintained in accordance with *FORWARD'S* installation, operation and maintenance instructions. Excluded from this warranty are the rolling bridge jacks, radius turn plates, and low-rise pad lifts.

This warranty runs in favor of the **ORIGINAL** purchaser only and does not cover normal maintenance or adjustments, damage or malfunction caused by improper handling, installation, abuse, misuse, negligence, carelessness of operation, or normal wear and tear. In addition, this warranty does not cover equipment when repairs have been made or attempted by anyone other than a *FORWARD* authorized service representative.

THIS WARRANTY IS EXCLUSIVE AND IS IN LIEU OF ALL OTHER WARRANTIES EXPRESSED OR IMPLIED INCLUDING ANY IMPLIED WARRANTY OR MERCHANTABILITY OR ANY IMPLIED WARRANTY OF FITNESS FROM A PARTICULAR PURPOSE, AND ALL SUCH IMPLIED WARRANTIES ARE EXPRESSLY EXCLUDED.

THE REMEDIES DESCRIBED ARE EXCLUSIVE AND IN NO EVENT SHALL FORWARD MANUFACTURING COMPANY, NOR ANY SALES AGENT OR OTHER COMPANY AFFILIATED WITH IT OR THEM, BE LIABLE FOR SPECIAL CONSEQUENTIAL OR INCIDENTAL DAMAGES FOR THE BREACH OF OR DELAY IN PERFORMANCE OF THIS WARRANTY. THIS INCLUDES, BUT IS NOT LIMITED TO, LOSS OF PROFIT, RENTAL OR SUBSTITUTE EQUIPMENT OR OTHER COMMERCIAL LOSS.

This warranty shall be governed by the laws of the State of Texas, and shall be subject to the exclusive jurisdiction of the Court in the State of Texas in the County of Tarrant.

## CONDITIONS

**PRICES :** Prices and specifications are subject to change without notice. All orders will be invoiced at prices prevailing at time of shipment. Prices do not include any local, state or federal taxes.

**RETURNS:** *FORWARD* products may not be returned without written approval from *FORWARD*. Returns are subjected to a credit deduction to cover transportation cost, 10% handling charge, and any necessary reconditioning costs.